

IMPORTANT SAFETY INSTRUCTIONS

1. Unlike traditional dimming controls, SWITCHEX + R1 requires unique wiring steps. Read all warnings and installation instructions thoroughly.
2. This product must be installed in accordance with the applicable installation code by a person familiar with the construction and operation of the product and the hazards involved.
3. Install in accordance with national and local electrical code regulations.
4. This product is intended to be installed and serviced by a qualified, licensed electrician.
5. Turn off electrical power before modifying the lighting system in any way.
6. Do not install this system in damp/wet locations.
7. To reduce the risk of fire and overheating, make sure all connections are tight, and use the gang box with minimum dimensions as recommended.
8. Only use copper wiring. Use wires rated for at least 194°F (90°C) and certified for use with external connection of electrical equipment.
9. Ensure applicable wire is installed between driver, fixture, and any controls in-between. When choosing wire, factor in voltage drop, amperage rating, and type (in-wall rated, wet location rated etc.). Inadequate wire installation could overheat wires, and cause fire.
10. Do not install in environment where excessive heat may exist (ex. close proximity to fireplace, etc.) See Ambient Temperature ratings.
11. Do not modify product beyond instructions or warranty will be void.
12. Actual color may vary from what is pictured on this sheet and other print materials due to the limitations of photographic processes.
13. We reserve the right to modify and improve the design of our fixtures without prior notice. We cannot guarantee to match existing installed fixtures for subsequent orders or replacements in regards to product appearance, CCT, or lumen output.

SAVE THESE INSTRUCTIONS

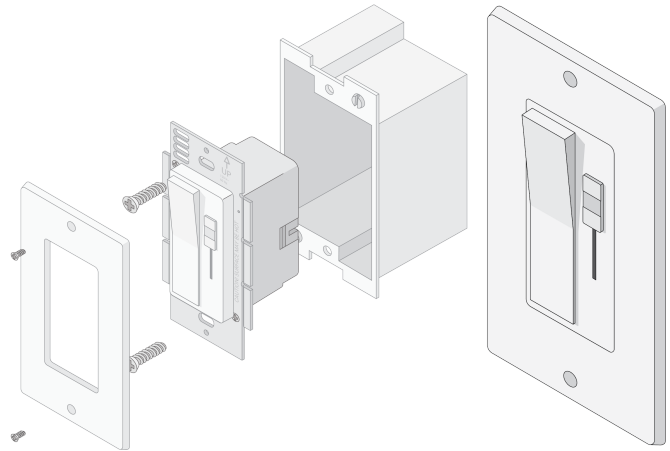

Supplied Accessories

SWITCHEX+ R1

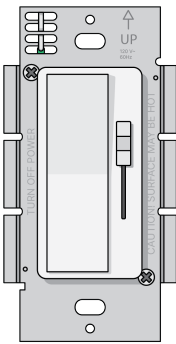

Voltage Partition

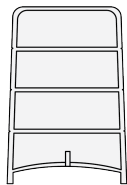

Twisted Wire Connector (7)



Mounting Screws (2)

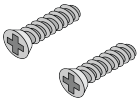

Tools For Install

Flat-head screwdriver

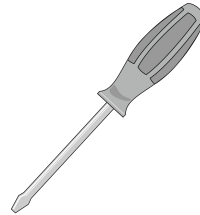

Phillips-head screwdriver

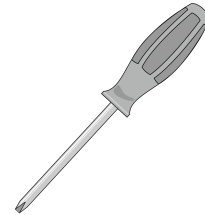

Pliers

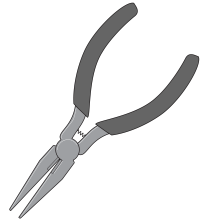

Wire Strippers

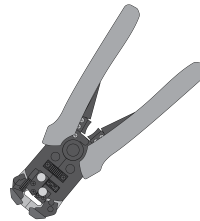

1. Turn Power Off at Circuit Breaker

SHOCK HAZARD! May result in serious injury or death. Turn power OFF at circuit breaker prior to installation.

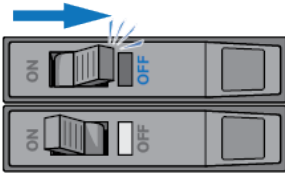

2. Determine Location to Install Components

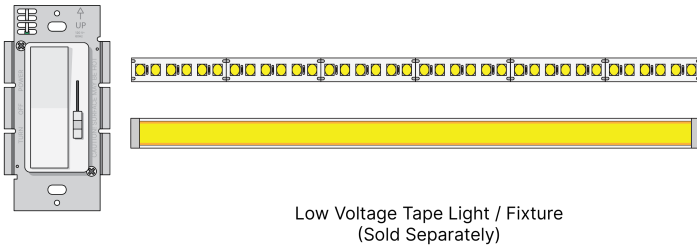

3. Remove Existing Switch (if necessary)

1. Remove trim plate and switch mounting screws.
2. Pull switch from wall.
3. Identify wires connected to switch and mark wires if desired.
4. Disconnect wires from switch.

4. Operation

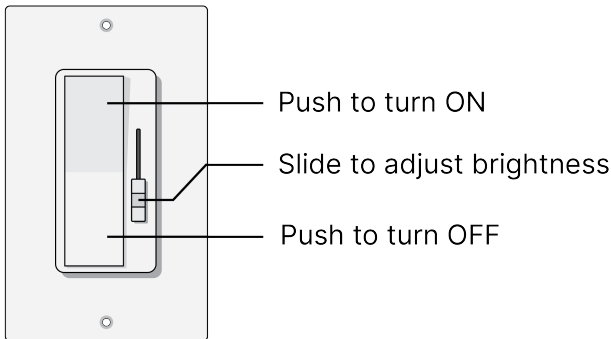

5. Attach Voltage Partition (Barrier)

A voltage barrier is provided, which separates high voltage and low voltage wires in the wall box. Attach before mounting.

5.1 - Shallow Wall Boxes

For shallow boxes, barrier can be shortened. Grip with pliers. Bend back and forth until fin breaks off.

Barrier size: 40mm wide x 56.6mm long

5.2 Highly recommended for user to use the gang box with integral partition.

5.3 Minimum gang box size:

60mm wide x 100mm long x 50mm deep.

5.4 A voltage barrier is provided, which separates high voltage and low voltage wires in the wall box. Attach before mounting.

5.5 Class 1 wiring

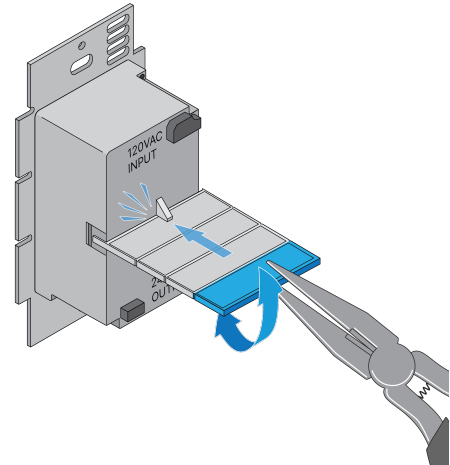

6. Wire SWITCHEX+ R1

SPECIAL WIRING INSTRUCTIONS!

SWITCHEX+ R1 requires unique wiring steps. Read thoroughly. For supply connection, use wires rated for at least 90°C.

6.1 - Strip wires on SWITCHEX+ R1

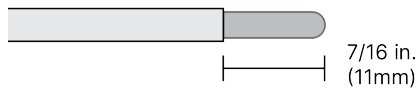

6.2 - Wire dimmer. Ensure Power is OFF.

- GND (GREEN): To ground wire box
- V+ (RED): To low voltage V+
- V- (BLUE): To low voltage V-
- N (WHITE): To 120V Neutral
- H (BLACK/RED): 3-Way Common
- B (BLACK): To 120V Line Hot
- R (RED): 3-Way T2 (Traveler)

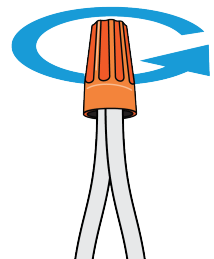

7. Installation (Cont'd)

- a. Wall only.
 - b. Class 1 wiring.
- Use fully rated (300V) wiring for the Class 2 luminaires if separate conduit openings (primary side) and Class 2 wires (secondary side)/or additional barriers are not practical, such as gang box without integral partition.
- c. For control of permanently installed Class 2 LED lamp fixtures only.
 - d. For supply connections use wire rated for at least 90°C.
 - e. This driver is constructed with Class 1 wiring at Class 2 output. Since this is intended for control of permanently installed Class 2 LED lamp fixtures, the installer should check the wiring class of the lamp fixture, and to determine the wiring method in accordance with local electrical code regulation.

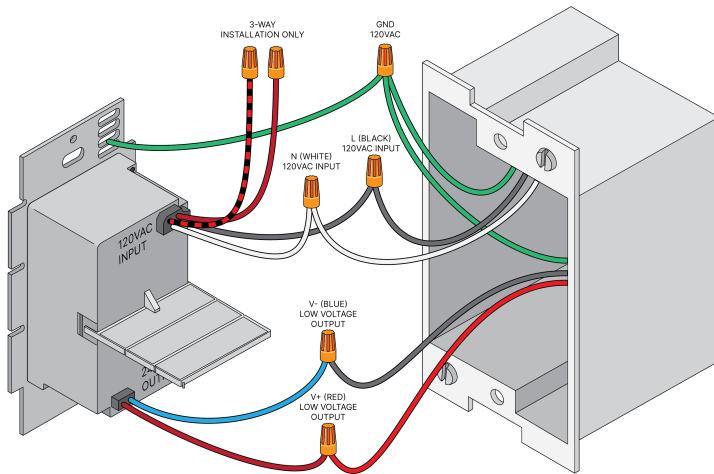

- f. Barrier and wall box dimensions refer to NEC Article 6 and shall be used to comply with the partition requirement of UL514C.

8. Mount SWITCHEX+ R1 to Wallbox and Attach Trim Plate

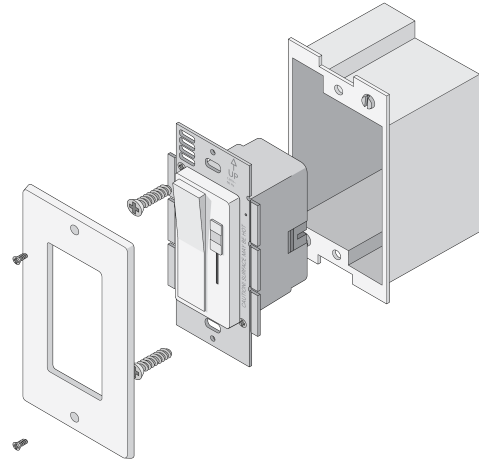

9. Turn Power On at Circuit Breaker

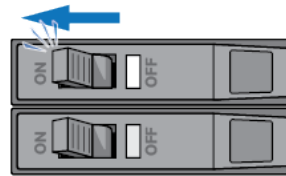

10. Auto-Calibration

- To initiate auto-calibration successfully, ensure the following conditions are met:
- The dimming slider should be set to the maximum position.
 - Allow 30 seconds in the ON position and the dimmer slider at full brightness for auto-calibration to be saved.

10.1 - Auto-Calibration Steps

It is recommended that auto-calibration takes place once the final light setup is wired.

- 1) Toggle SWITCHEX+ R1 on/off paddle to the OFF position.
- 2) Increase the dimming level to full brightness.
- 3) Toggle SWITCHEX+ R1 on/off paddle to the ON position.
- 4) Wait for 30 seconds for auto-calibration to complete.
 - During this time the luminaire will flash and dim on its own. Do not interrupt this process.
- 5) Verify dimming functionality using the dimmer slider.

System Diagrams

Mount using included mounting screws.

The following diagram is an example system design. For information regarding larger systems or systems not pictured below, please see our web page or contact technical support. Always review each component installation guide for detailed and up-to-date wiring instructions. Install in accordance with national and local electrical codes.

Other diagrams will vary based on power and dimming requirements.

Standard Dimmer System

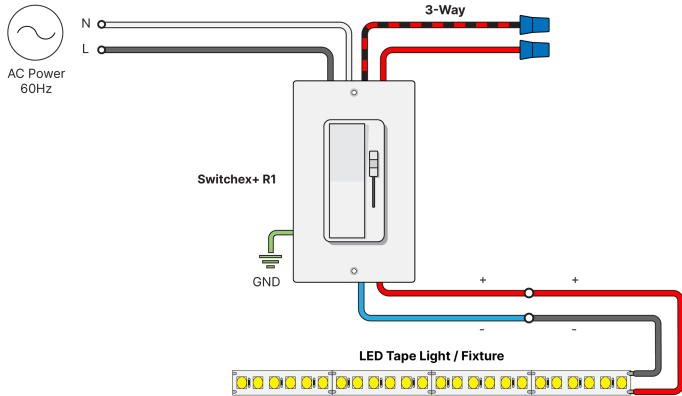

3-Way Dimmer System

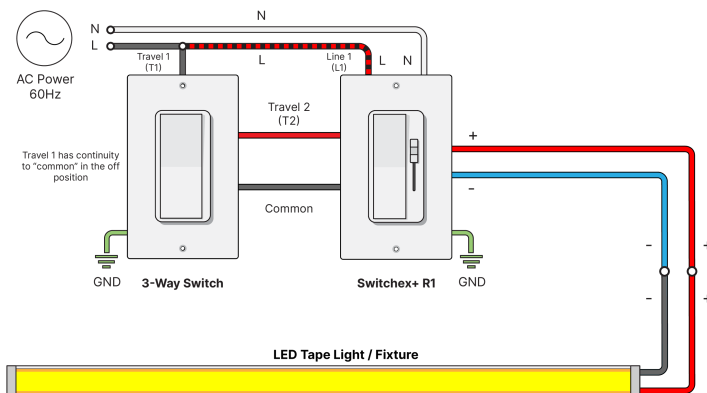

Quick Specs / Models

	Input	Output	Max Load
DI-SXR1-12V40W	120VAC 60Hz	12VDC	40W
DI-SXR1-12V60W		12VDC	60W
DI-SXR1-24V60W		24VDC	60W

Note: The typical minimum slider output voltage: 7.65V for 12V models and 15V for 24V models. 24V LED have a variance that some LED uses around 20V as min dim output voltage. The model is equipped for the 24V models to auto calibrate on different LED loads.

Troubleshooting

Symptom 1: Fixture does not illuminate

Common Cause

- Incorrect wiring. Polarity of Low Voltage V+ and V- are reversed.
- Circuit breaker is OFF or tripped.
- Incorrect voltage pairing of dimmer and fixture. 12V dimmer models will not power a fixture with a higher voltage rating.

Symptom 2:

• Different fixtures do not dim in sync.

- Fixture turns off at low dim level.
- Fixture strobos/flickers at low dim level.
- Dimmer buzzes excessively

Common Cause

- Only install 24VDC tape light or fixtures on the compatibility list.

Symptom 3: Fixture heats up excessively

Common Cause

- Incorrect voltage pairing of dimmer and fixture. Do not attach a 12VDC fixture to a 24VDC dimmer.
- Fixture is not compatible.

Symptom 4: Product does not dim consistently

Common Cause

- Disconnect from power and repeat calibration steps.