

**Important:** Read All Instructions Prior to Installation

## Function introduction

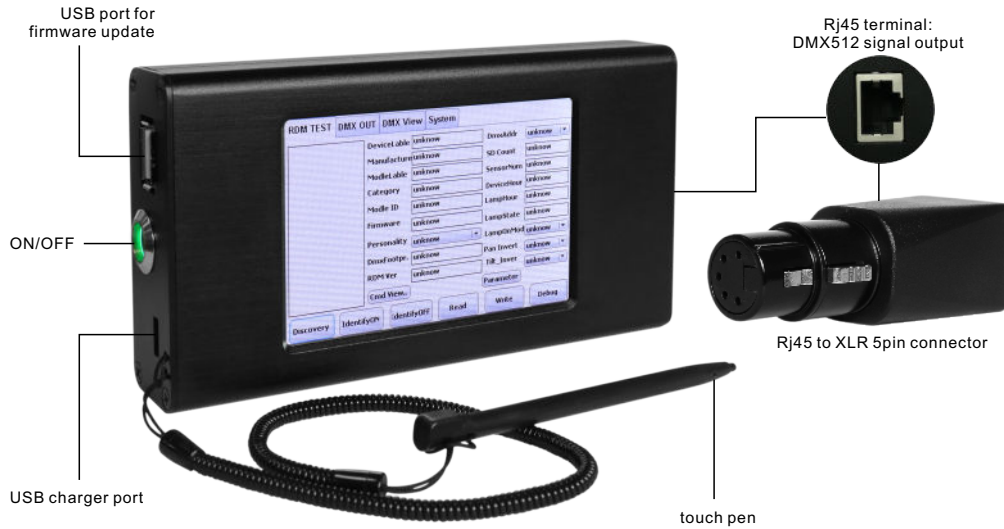

This device is designed for quick testing of RDM enabled DMX devices, RDM is a protocol that stands for Remote Device Management, which can remotely configure and monitor lamp devices through RS485 signal and solve the issue that DMX512 can not transmit bi-directionally. The signal transmission of this device complies to RDM protocol and DMX protocol specifications.

## Product Data

Attribute	Min. Value	Typical Value	Max. Value	Unit
Input Voltage	--	5Vdc	6Vdc	V
Input Current	--	500mA	500mA	mA
Ambient Temperature	-40°C	25°C	85°C	°C
Dimensions	130x25x70mm			

- Portable and powerful RDM tester
- Simple and easy to use interface
- Max. 512 DMX channels output, RJ45 port for DMX signal transmission
- Suitable for large project testing, no complicated DMX master controller required
- Supports RDM standard protocol testing
- Supports RDM user customized PID testing
- Supports manual DMX output
- Supports DMX signal view
- Built-in 2000mAh rechargeable lithium battery
- Supports firmware updating through USB port
- Supplied with a touch pen for smooth touch control
- Supplied with RJ45 cable
- Supplied with an RJ45 to XLR 5pin connector
- Supplied with USB cable for charging

## Safety & Warnings

- DO NOT install with power applied to device.
- DO NOT expose the device to moisture.

## Operation

### 1.RDM TEST

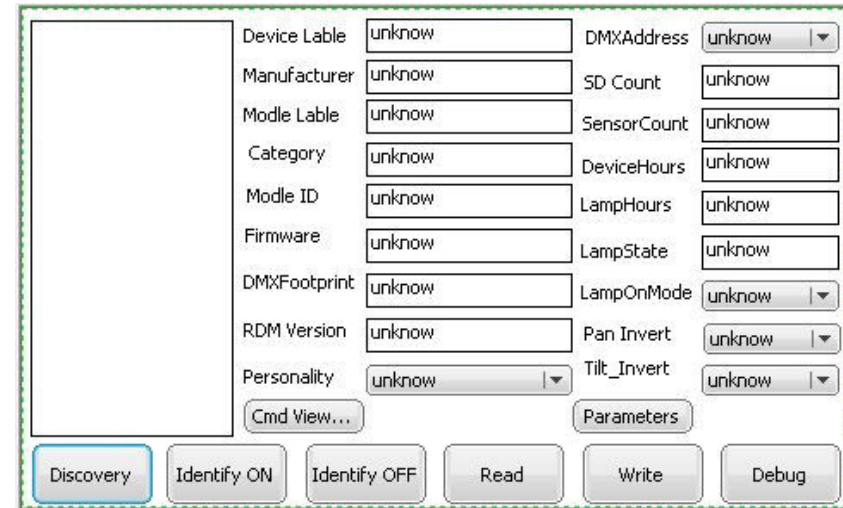

Above interface is RDM test interface, functions of each item are as follows:

- **Device Label:** Show the label name of the tested RDM slave device
- **Manufacturer:** Show the manufacturer name of the tested RDM slave device
- **Module Label:** Show the module label name of the tested RDM slave device
- **Category:** Show the device category of the tested RDM slave device
- **ModuleID:** Show the module ID number of the tested RDM slave device
- **Firmware:** Show the firmware version number of the tested RDM slave device
- **DmxFootprint:** Show the DMX channel quantity occupied by the tested RDM slave device
- **RDM Version:** Show the RDM version number of the tested RDM slave device
- **Personality:** Show the working mode quantity of the tested RDM slave device
- **DmxAddress:** Show the DMX address number of the tested RDM slave device
- **SD Count:** Show the child device quantity of the tested RDM slave device
- **Sensor Count:** Show the sensor quantity of the tested RDM slave device
- **DeviceHours:** Show the operating time of the tested RDM slave device
- **LampState:** Show the lamp status of the tested RDM slave device
- **LampOnMode:** Show the lamp on mode of the tested RDM slave device
- **Pan Invert:** Show the invert status of X axis of the tested RDM slave device
- **Tilt Invert:** Show the invert status of Y axis of the tested RDM slave device
- **Discovery:** Used to discover RDM slave device when pressed, if slave devices are discovered, the UID number of the slave devices will be listed on the above list box
- **Identify ON:** Enables to identify the selected slave devices UID number
- **Identify OFF:** Disables to identify the selected slave devices UID number
- **Read:** Read the parameters of selected slave devices UID number, the parameters include all parameters showed on the interface, if the slave device supports command SLOT\_DESCRIPTION, name of each slot will be read and showed on the status box of CMD View
- **Write:** Write in parameters of selected UID number devices, the parameters including Personality, DmxAddress, LampOnMode, SetPanInvert, TiltInvert will be written in. If any of the 5 commands is not supported by the selected slave device, system will not write in that command.

- **Debug:** Press to enter into RDM protocol Debug mode
- **Cmd View:** Press to enter into command view window, when operate any RDM command on RDM TEST interface, all master device and slave device information state will be showed on this window, so that RDM signal can be monitored
- **Parameters:** Press to show supported RDM command information of the selected UID number device, the supported the RDM command information will be showed on CMD View list box, please open CMD View window to check information between RDM and slave device.

**Notes**

- all items on the initialized interface will be unknown, if a slave device does not support some of the commands, the item will be showed as unknown
- If a slave device does not support a PID, Not Support PID will be showed on CMD View window
- If a slave device does not response, NOT ACK will be showed on CMDView Window
- If feedback packet verify error, CheckSumError will be showed on CMDView Window
- If feedback packet is not RDM packet, Respond Package Error will be showed on CMDView Window

**2.RDM DEBUG**

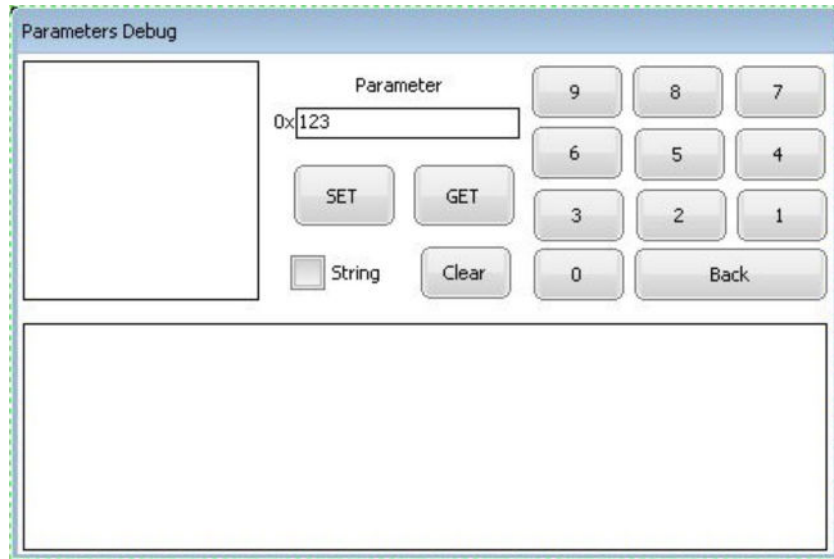

On RDM TEST interface, press Debug button to enter into RDM debug interface, the selected UID number will be showed on the title column, all supported RDM command parameters will be showed on the list box at upper left corner, following parameters are mandatory in RDM protocol:

- SUPPORTED\_PARAMETERS
- PARAMETER\_DESCRIPTION
- DEVICE\_INFO
- SOFTWARE\_VERSION\_LABEL
- DMX\_START\_ADDRESS
- IDENTIFY\_DEVICE

The above 6 commands will be force inserted to the start of the list box, then user can select parameters that the RDM slave device itself owns by pressing the 10 keys on the right of the parameter input box to input parameter. RDM commands will be sent using hex, which means the parameter input is hex, for instance if the parameter to be set is a 1 byte parameter 1, then we should input 01, if RDM commands support 2 byte parameters, then we should input 0001, for instance when we set DMX\_START\_ADDRESS parameter, this command supports 2 byte PD, we must input 0001, which means 2 byte parameter, if the check box String is ticked, then the parameter will be sent in character string mode, input 0001, the character string 0001 will be sent, all detailed command packet data that master device sends out and slave device returns back will be listed in the list box.

Press SET button to send out selected command parameter.

Press GET button to get selected command parameter.

Press Clear button to clear information in the list box.

**Note: if a command does not support PD parameter, please press BACK to clear parameter in the input box, otherwise system will write the parameter in command data packet.**

**3.DMX OUT**

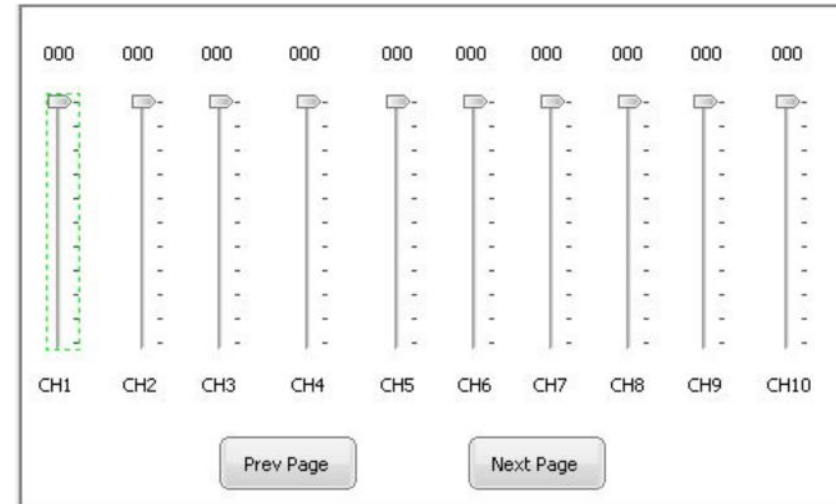

This device supports manual DMX output, if enters into DMX OUT interface, system will start DMX generator, and generate DMX signal output, the interface support 512 channels signal output, which can be selected using buttons Prev Page and Next Page, DMX signal value can be controlled by pushing the slider.

**4.DMX View**

RDM TEST	DMX OUT	DMX View	System
CH001:000	CH002:000	CH003:000	CH004:000
CH005:000	CH006:000	CH007:000	CH008:000
CH009:000	CH010:000	CH011:000	CH012:000
CH013:000	CH014:000	CH015:000	CH016:000
CH017:000	CH018:000	CH019:000	CH020:000
CH021:000	CH022:000	CH023:000	CH024:000
CH025:000	CH026:000	CH027:000	CH028:000
CH029:000	CH030:000	CH031:000	CH032:000
CH033:000	CH034:000	CH035:000	CH036:000
CH037:000	CH038:000	CH039:000	CH040:000
CH041:000	CH042:000	CH043:000	CH044:000
CH045:000	CH046:000	CH047:000	CH048:000
CH049:000	CH050:000	CH051:000	CH052:000
CH053:000	CH054:000	CH055:000	CH056:000
CH057:000	CH058:000	CH059:000	CH060:000
CH061:000	CH062:000	CH063:000	CH064:000
CH065:000	CH066:000	CH067:000	CH068:000
CH069:000	CH070:000	CH071:000	CH072:000
CH073:000	CH074:000	CH075:000	CH076:000
CH077:000	CH078:000	CH079:000	CH080:000
CH081:000	CH082:000	CH083:000	CH084:000
CH085:000	CH086:000	CH087:000	CH088:000
CH089:000	CH090:000	CH091:000	CH092:000
CH093:000	CH094:000	CH095:000	CH096:000

<< >> NO DMX....

This device supports DMX signal monitor function, if it enters into DMX View interface, system will read real time DMX bus data, and showed on the DMX View interface, which is convenient for user to monitor and real time DMX bus data can be selected using buttons Prev Page and Next Page.

## 5. Screen Calibration

When touch screen is not sensitive for touch control, we need to calibrate the screen and initialize the calibration parameter, please follow the steps below:

1. Power off the device
2. Use the touch pen or a finger to press and hold down the touch screen
3. Power on the device when press and hold down touch screen
4. Keep holding the screen for 2 seconds after power on the device then release the screen, the program will enters into calibration mode, then press the 4 appeared cross sight beads one by one to complete calibration.

## Wiring diagram

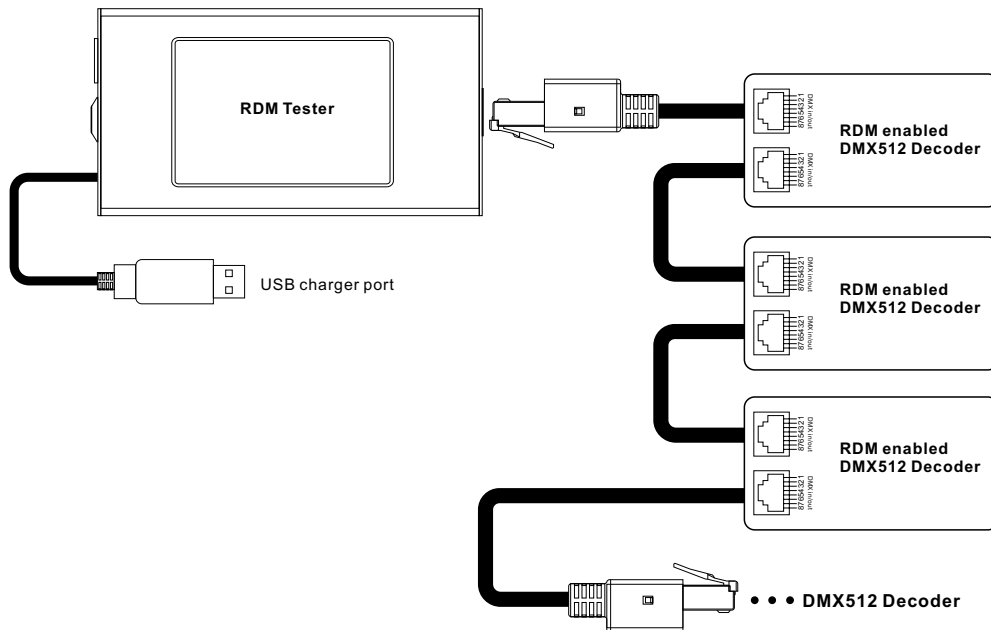

**Note:** the supplied RJ45 to XLR 5pin female connector can be used to connect the tester to DMX devices with XLR 5pin male connector.