

NODE 2

CONVERT ART-NET AND sACN TO DMX

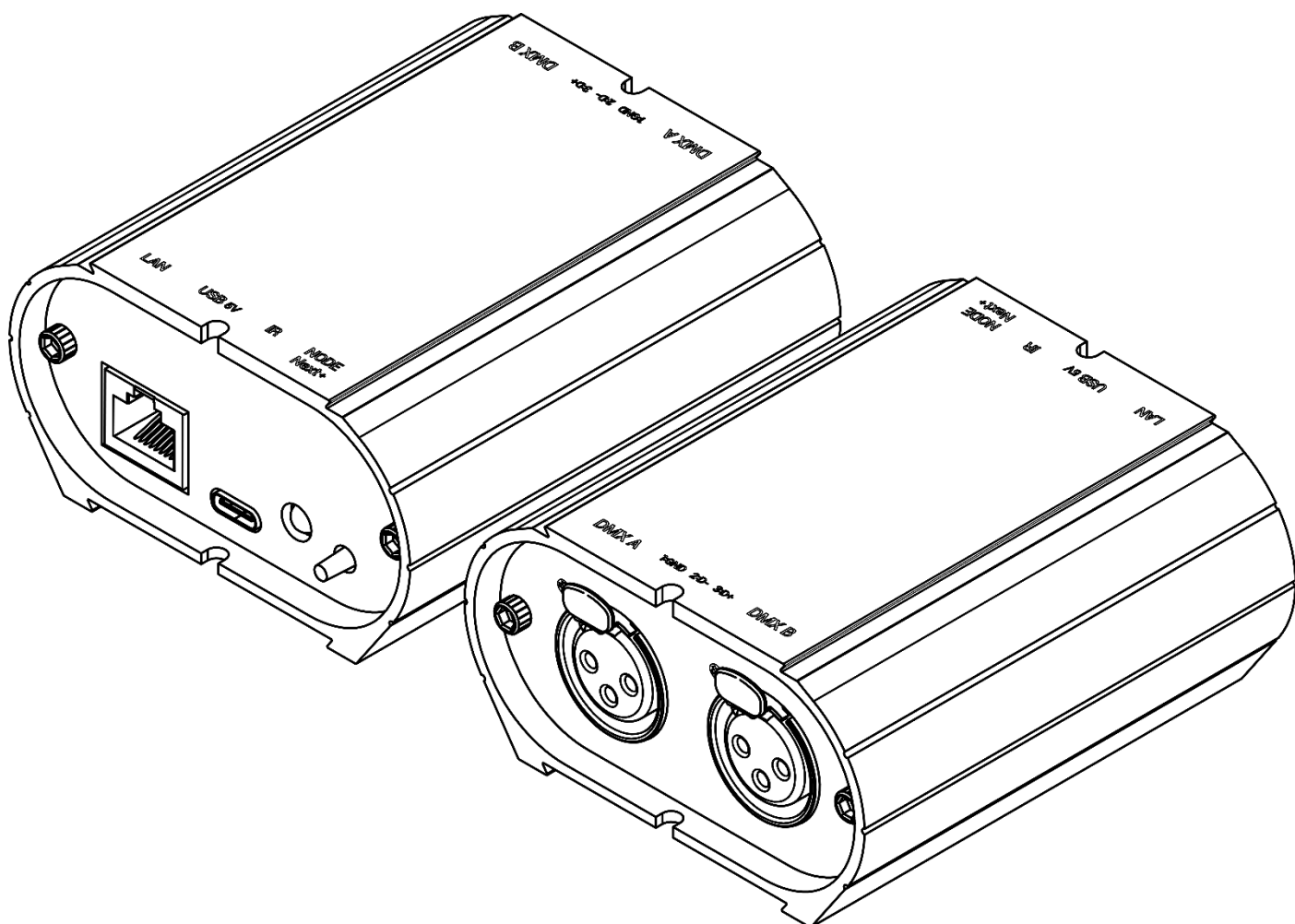



CHROMATEQ

Technical Manual & Quick Start Guide
Stand Alone Interface USB & Ethernet

Congratulations on your purchase of a CHROMATEQ controller.

Please read this manual carefully and thoroughly before using Chromateq Node 2.

The information presented here provides a useful introduction to the wide range of features, settings and functions available in this compact and versatile device.

This Node 2 Technical Manual is written in English and French.
(Le manuel technique du Node 2 est rédigé en anglais et en français.)

All products and software are developed and designed in France.

CHROMATEQ SARL
191 Allée de Lauzard
34980 St Gély du Fesc
FRANCE
VAT: FR18521458034
Siret: 52145803400027

Web & E-mail: www.chromateq.com
Phone: +33 952210755 / +86 13422062209

Whatsapp: +8613422062209
Wechat: Chromateq
QQ: 2908265661

Twitter: <https://twitter.com/Chromateq>
Facebook: <https://www.facebook.com/ChromateqCompany/>
YouTube: <https://www.youtube.com/c/chromateq>

Copyright Information and Disclaimer

Copyright © 2021 – CHROMATEQ. All rights reserved.

No part of this publication may be reproduced, distributed, or transmitted in any form or by any means, including photocopying, recording, or other electronic or mechanical methods, without the prior written permission of the publisher, except in the case of brief quotations embodied in critical reviews and certain other none commercial uses permitted by copyright law.

For permission requests, write to the publisher, addressed "Attention: Permissions Coordinator," at the address above.

Trademark Credits

Microsoft and Windows are U.S. registered trademarks of Microsoft Corporation. Art-Net™ – Designed by and Copyright Artistic License Holdings Ltd. All other products mentioned herein may be trademarks of their respective ® companies.

Package Contents

1x CLUB-E 1024
1x USB cable
1x download link for software and technical documentation

Please note: Check the package contents and the condition of the interface after unpacking! Contact your supplier if something is missing or damaged. Do not use the device if it seems to be damaged!

Contents

Contents	3
1. Introduction	4
2. Technicals features	4
3. Housing connectivity	5
Front Panel.....	5
Rear Panel.....	5
4. Connection & USB driver	6
5. Connection & Ethernet Setup	7
DHCP switchover / Static IP.....	7
DHCP Connection	7
Static IP connection.....	8
IP address reset	8
6. NODE mode setup	9
Setup with the software.....	9
Network setup	9
NODE Art-Net or sACN mode.....	9
Setup with the DeviceTool	10
Network setup	10
NODE Art-Net or sACN mode.....	10
Setup with a Web Browser.....	11
7.Udp, Broadcast, Unicast, Multicast	11
8.Connecting to a wifi router	12
9. Reset the default device	13
10. NODE wiring diagram	14
11.Housing dimensions	15
Front panel.....	15
Back panel	15
Tops panel	15
12. Detecting NODEs on the network.....	16
13.Troubleshooting	17

1. Introduction

The NODE-2 is an easy-to-use solution for your projects.

It converts Art-Net and sACN signals into DMX 512 signals on 2 DMX lines.

The device can be configured via USB and Ethernet using DEVICETOOL software, the Wi-Light 2 application or a web browser.

2. Technicals features

Input	USB-C & RJ45 Ethernet (10Mb/s)
DMX Outputs	2x512 or 1024 on XLR 3 broches (XLR 5 en option)
Input signals	Art-Net & sACN for x2 universes (2x512 channels)
Modes supported	UDP, Broadcast, Unicast, Multicast, fixed IP, DHCP
Power supply	5V, 0,3A via USB-C
IP rating	IP22
Dimensions (mm)	H : 45 (1.77 in) / L : 90 (3,54 in) / l : 80 (3.15 in)
Net Weight	0.19 Kg (0.42 lbs)
Gross weight	0.31 Kg (0.68 lbs)
Power / Consumption	1,5 W
High Voltage Protection	Yes, fuses & diodes
Housing	Anthracite Grey, Brushed Aluminium
Operating environment	Indoor
Storage	keep dry
Operating Temperature	- 40 to +85 C°
Certifications	CE, RoHS
International Warranty	yes, 3 years
System Compatibility	Windows (7 & higher), MAC OS X (10.13 & higher) et Linux (64 Bits, Debian, Redhat, Archlinux, Raspberry Pi)

3. Housing connectivity

Front Panel

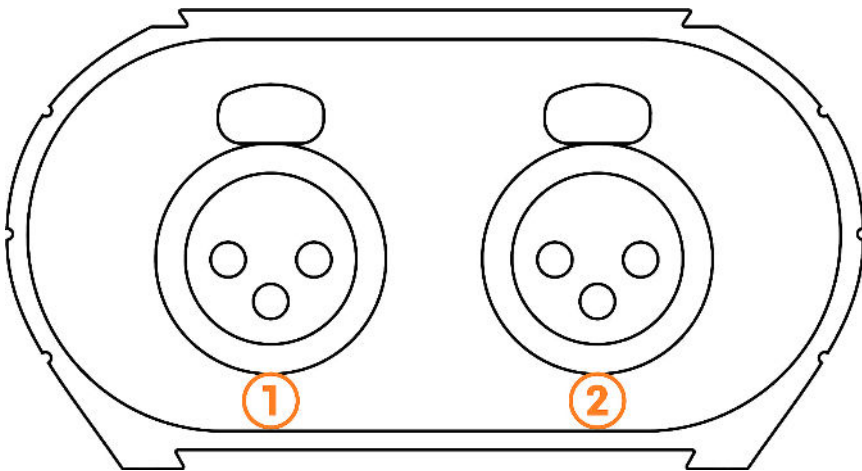

- 1 - Output DMX A,
- 2 - Input / Output DMX B

XLR Connector 3 pins

- 1: Ground
- 2: Data -
- 3: Data +

Rear Panel

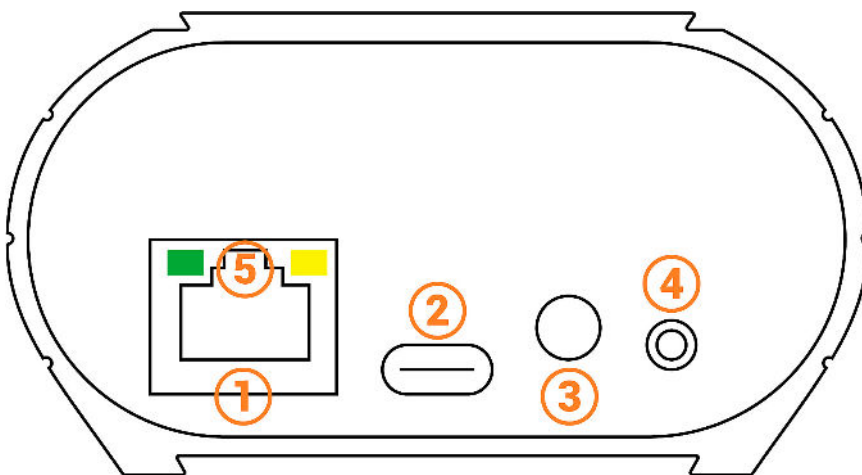

- 1 - RJ45, Network (LAN) connection
- 2 - USB-C, power connector (5V. DC, 0.3A)
- 3 - Infra-red receiver LED, optional
- 4 - Modes selector (5 s.) Art-Net or sACN
- 5 - LEDs signals : green (G) et Yellow (Y)

LED signal correspondence

G on + Y off	No signals
G fast blink + Y off	USB signal
G on + Y fast blink	Ethernet signal
G slow blink + Y off	Stand Alone DMX
G on + Y slow blink x1	NODE Mode converter Art-Net to DMX
G on + Y slow blink x2	NODE Mode converter sACN to DMX

4. Connection & USB driver

The device can be connected via USB. USB drivers must be installed to communicate with the device and modify settings.

USB driver installation is only required for Windows at the end of installation. Drivers for Mac and Linux systems are installed automatically.

Checking USB drivers :

In Windows Device Manager. Check that the device icon is visible in "USB bus controllers".

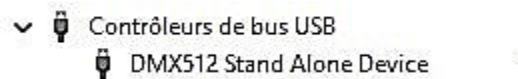

If drivers are not installed, the Windows Device Manager lists a device with a yellow warning.

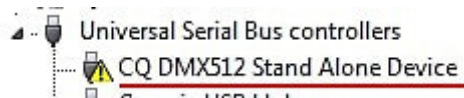

Under Mac OS, simply check the USB device tree to see "DMX 512 Stand Alone Device".

Under Linux, use the "lsusb" command to view the "DMX 512 Stand Alone Device" list.

After installing the control software and USB drivers

- Connect the device with the USB cable.
- Start DEVICETOOL and select "Open USB Device" to modify settings.
- Start the software and select the "Tools" menu, then "Options" to modify parameters in the "Device" page.

All connected and detected devices are always listed.

5. Connection & Ethernet Setup

The device can also be connected via Ethernet. Ethernet communication must be established to communicate with the device and modify parameters.

Ethernet communication can be established in several ways. Directly, via an IP switch or Wifi router. The device is in DHCP mode by default.

Initial steps required

- Connect the device to the local area network (LAN) or computer via an RJ45 Ethernet cable.
- Supply power via USB cable (5V DC, 0.3A).
- Connect the computer to the same network (LAN) or interface via an RJ45 Ethernet cable.

DHCP switchover / Static IP

In DHCP mode, if there is no response from a DHCP server after a short time, the interface will use static IP mode with its default IP address and wait for the next DHCP request to use DHCP mode. It will therefore still be possible to connect directly to the computer in static IP MODE. The device is in DHCP mode by default.

DHCP Connection

DHCP mode enables communication with devices via a DHCP server, which automatically assigns and manages IP addresses for each device. The DHCP server may be an IP Switch, Router or other type.

The device is in DHCP mode by default.

It is automatically detected by the software when the computer is also connected via DHCP to the same network or with a static IP address of the same range.

The advantage of DHCP is that the DHCP server automatically manages the IP addresses of connected devices. So you don't need to know the exact IP of your device to connect to it. However, IP addresses change regularly, which can make installation less reliable.

Setting up the DHCP connection

- After the initial steps have been completed.
- If the device is in DHCP mode (default mode).
- Configure the computer in DHCP mode.

- Start the software or DEVICETOOL by selecting "Open Ethernet Device".

Static IP connection

Static IP mode enables direct communication with an interface without necessarily passing through another device such as an IP switch, router or access point. It is also used on local networks without a DHCP server.

Static IP mode can also be used to freeze a network configuration, bringing greater stability to installations set up with multiple devices using an IP switch or router.

The device's default Static values are :

IP address: 192.168.0.5

Subnet mask: 255.255.255.0

Setting up a static IP connection

- After the required initial steps have been completed.
- If the device is in Static IP mode.
- Set the computer's IP address to an identical IP address range such as 192.168.0.x. With "x" not equal to 5 to avoid conflicts of identical IP addresses on the network.
- Set the subnet mask to 255.255.255.0.
- Start software or application.

In this way, the device will be recognized when the software starts up, since it is in the same IP address range.

IP address reset

If you don't know the device's default IP address, use the USB connection and the software or settings tools to check or modify its IP address.

6. NODE mode setup

Setup with the software

Network setup

Access the device options window:



In the "Ethernet" tab, check "DHCP" to put the device in DHCP mode and apply.

To put the device in static IP mode, uncheck "DHCP" and enter the IP address, subnet mask, gateway, and name, then apply.

NODE Art-Net or sACN mode

The device's Node mode makes it possible to convert Art-Net and sACN signals to DMX.

In the Node part, select Node Art-Net to change the settings you want.

It is possible to configure names with "Short Name" and "Long Name".

It is possible to change the DMX ports or outputs of the Node by modifying the "SubNet" and "DMX Universe", and then apply.

Select Node sACN to choose DMX and applied Universes.

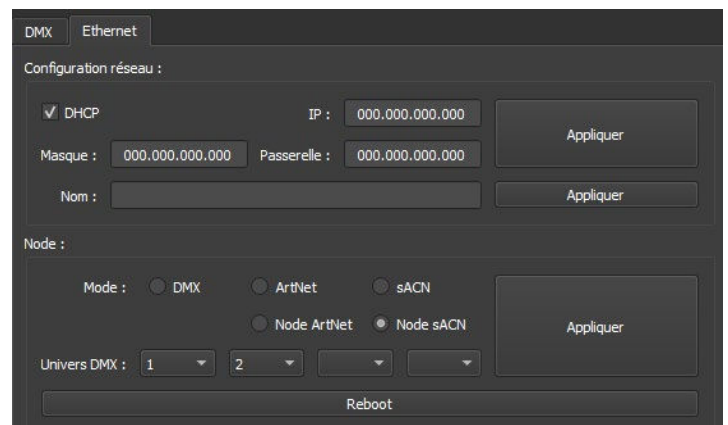
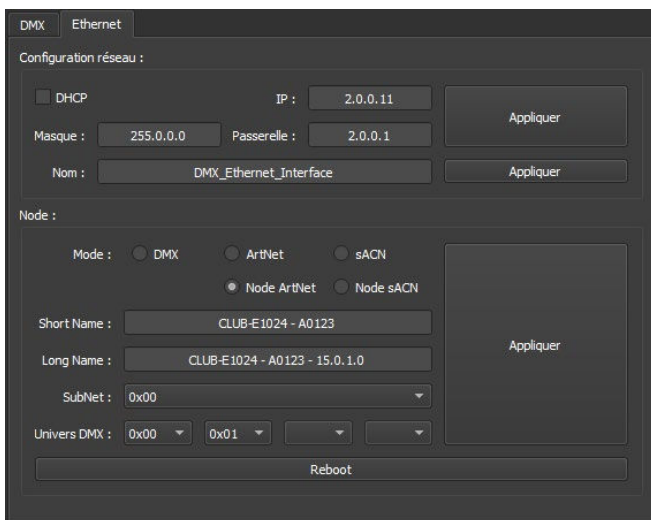

Press "Apply" to take into account the new settings.

To use the device in the selected mode, you must restart the device after configuration by unplugging it from the power supply.

It is also possible to switch between Art-Net and sACN mode with long support (5s.) on the Device Mode button and following the network configuration of the device.

Setup with the DeviceTool

Network setup

Open the device via USB or Ethernet with the option "Open USB Device" or Open "Ethernet Device". Select the "Network" tab.

In the "Ethernet" tab, check "DHCP" to put the device in "DHCP" mode and apply.

To put the device in static IP mode, uncheck DHCP and enter the IP address, subnet mask, gateway, and name, then apply.

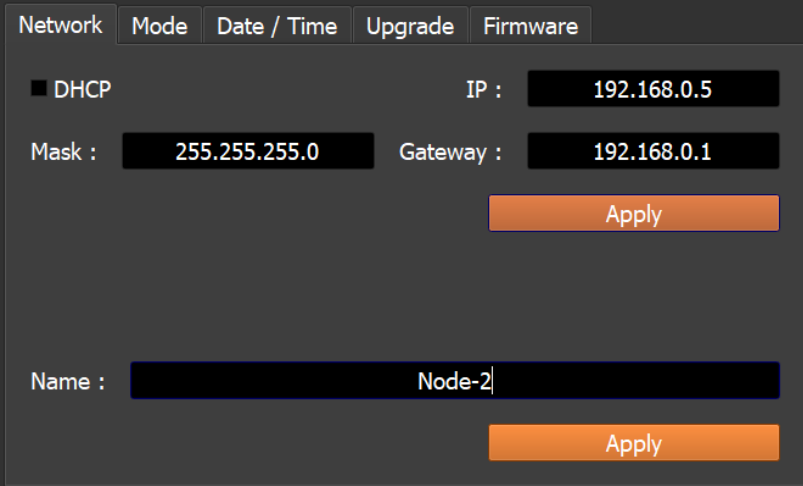

The screenshot shows the 'Network' configuration window in DeviceTool. At the top, there are tabs for 'Network', 'Mode', 'Date / Time', 'Upgrade', and 'Firmware'. The 'Network' tab is active. Below the tabs, there is a 'DHCP' checkbox which is checked. To the right of the checkbox, the IP address is set to '192.168.0.5'. Below the IP field, the 'Mask' is set to '255.255.255.0' and the 'Gateway' is set to '192.168.0.1'. There is an 'Apply' button below the gateway field. At the bottom of the window, there is a 'Name' field containing 'Node-2' and another 'Apply' button.

NODE Art-Net or sACN mode

The device's Node mode makes it possible to convert Art-Net and sACN signals to DMX.

Open the device via USB or Ethernet with the option "Open USB Device" or Open "Ethernet Device". Select the "Fashion" tab.

select Node Art-Net to change the desired settings.

It is possible to configure names with "Short Name" and "Long Name".

It is possible to change the DMX ports or outputs of the Node by modifying the "SubNet" and "DMX Universe", and then apply.

Select Node sACN to choose DMX and applied Universes.

Press "Apply" to take into account the new settings.

To use the device in the selected mode, you must restart the device after configuration by unplugging it from the power supply.

It is also possible to switch between Art-Net and sACN mode with long support (5s.) on the Device Mode button and following the network configuration of the device.

Setup with a Web Browser

This feature is not currently available.

7.Udp, Broadcast, Unicast, Multicast

Art-Net and sACN are communication protocols based on the UDP/IP standard. These 2 protocols integrate DMX frames into Ethernet frames allowing simpler and more convenient wiring with the use of IP switches or WIFI terminals.

Several DMX lines can be encapsulated in an Ethernet frame and therefore reduce wiring to 1 single Ethernet line for X DMX lines.

Art-Net network data is transmitted in broadcast or unicast mode.

Unicast is preferable when using multiple devices on the network and when managing more than 10 DMX universes.

sACN network data is transmitted in Unicast and Multicast.

8. Connecting to a wifi router

The device's RJ45 port allows a wired connection to a local network, but it is also possible to connect to it via WIFI via a WIFI router.

The illustration below is an example of a configuration using a third-party mini WiFi router to allow a wireless connection. Other descriptions of these routers can be "hotspot", "hub", "dongle", "bridge", "repeater", etc.

Note: It is also possible to connect multiple devices to the WiFi router or extend the available RJ45 ports with a Switch IP.

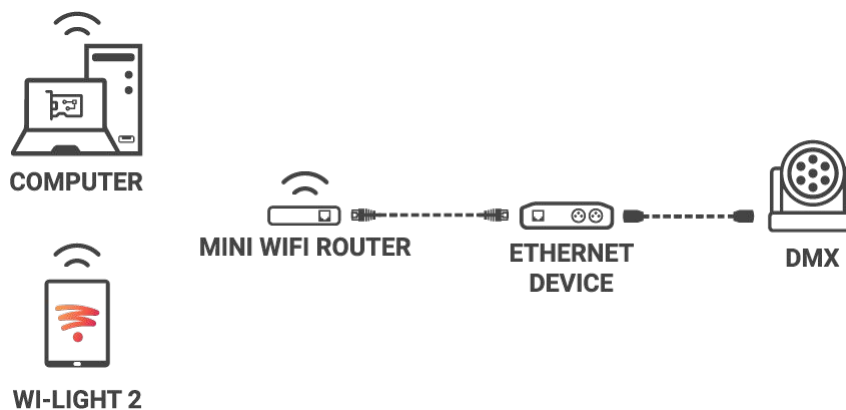

Implementation of the WIFI network:

- Set up the WiFi router as a Hotspot to create a new access point.
- Or configure the WiFi router as "Bridge" or repeater to join an existing network.
- It is possible to configure the router in Static IP or DHCP.
- In DHP (default mode of a router) IP addresses are dynamically assigned on the network by the DHCP server.
- After configuring the router, connect the RJ45 ports and configure the device in DHCP or static IP mode.
- Once the device is connected to the router, it can be used and visible on the network.

9. Reset the default device

To restore the default values and reset your device, reconfigure the device via USB or Ethernet with the software or DEVICETOOL or application and restart it to take into account the new mode and settings.

It is also possible to change mode directly on the device with a 5 second long press on the mode button.

10. NODE wiring diagram

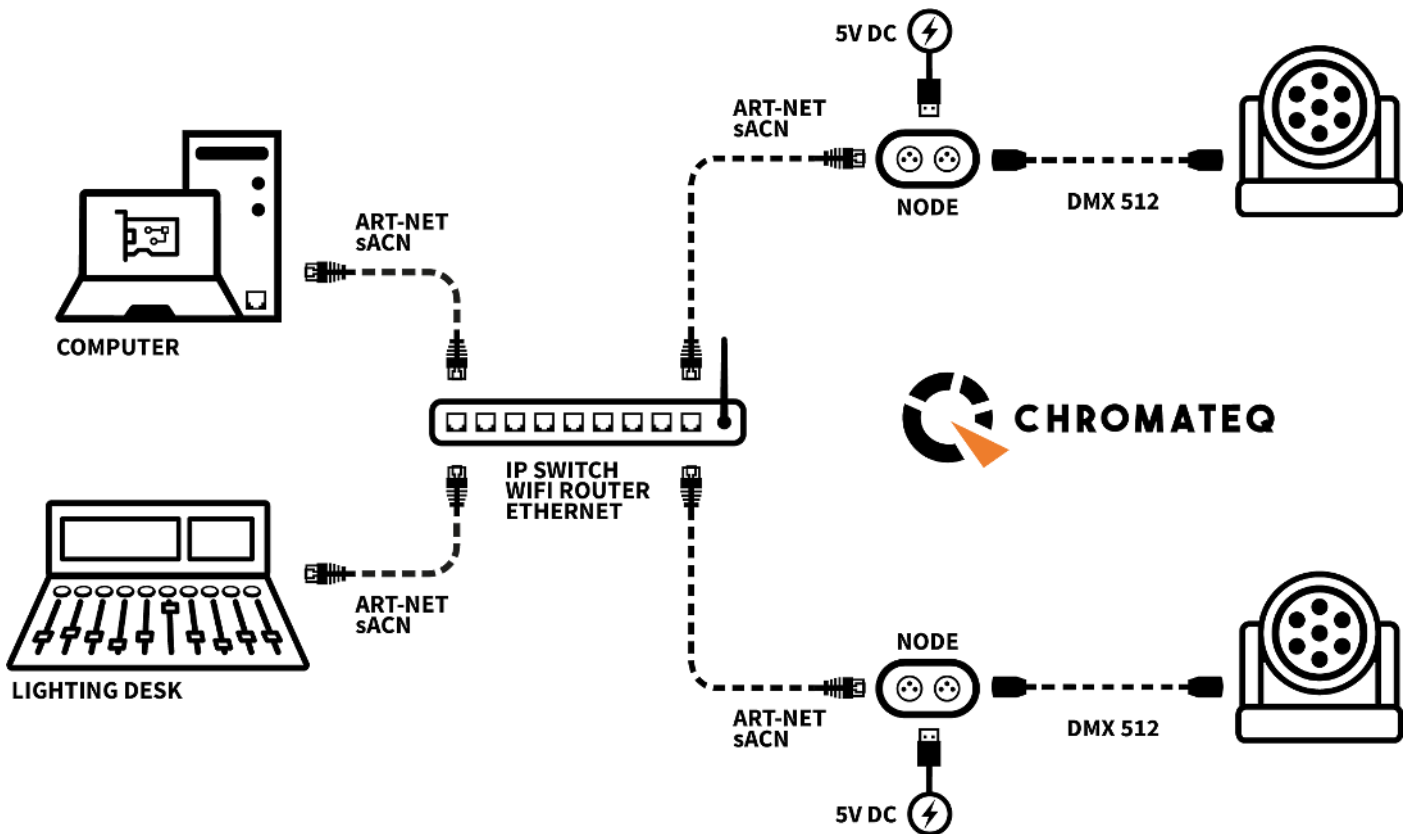

11.Housing dimensions

Front panel

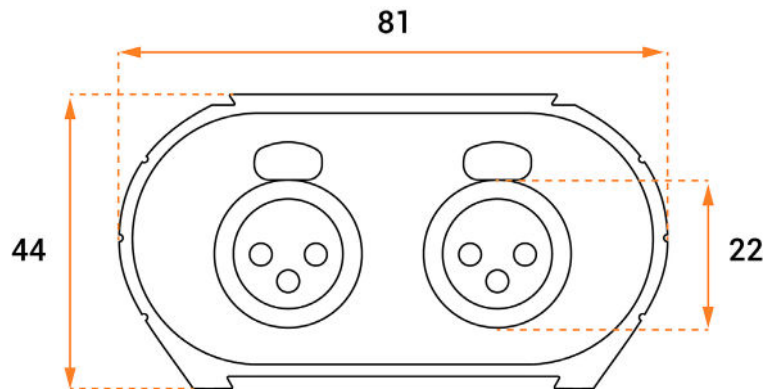

Back panel

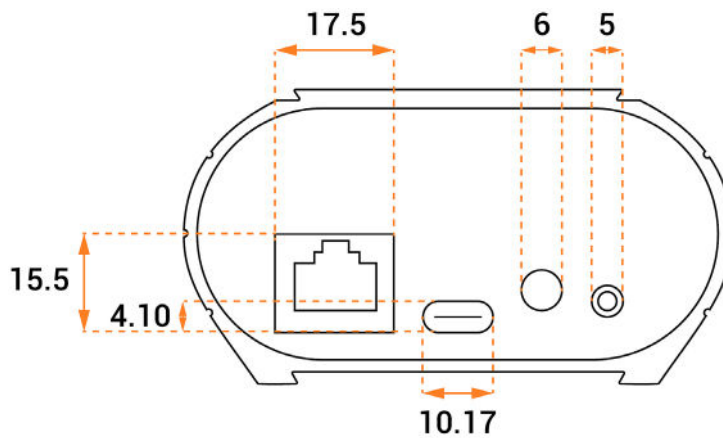

Tops panel

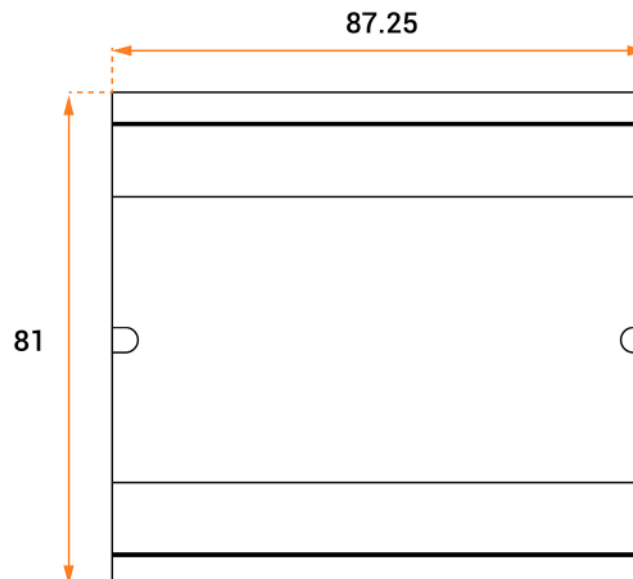

12. Detecting NODEs on the network

It is possible to connect multiple devices to the same network in order to multiply the DMX output universes.

Audit of previous steps

- Assigning IP addresses and subnet masks.
- Configuring devices via the software or DeviceTool.
- Connecting devices to the network.
- Powering devices.

If the steps have been followed, the devices are visible on the network by the software or by other devices compatible with Art-Net frames.

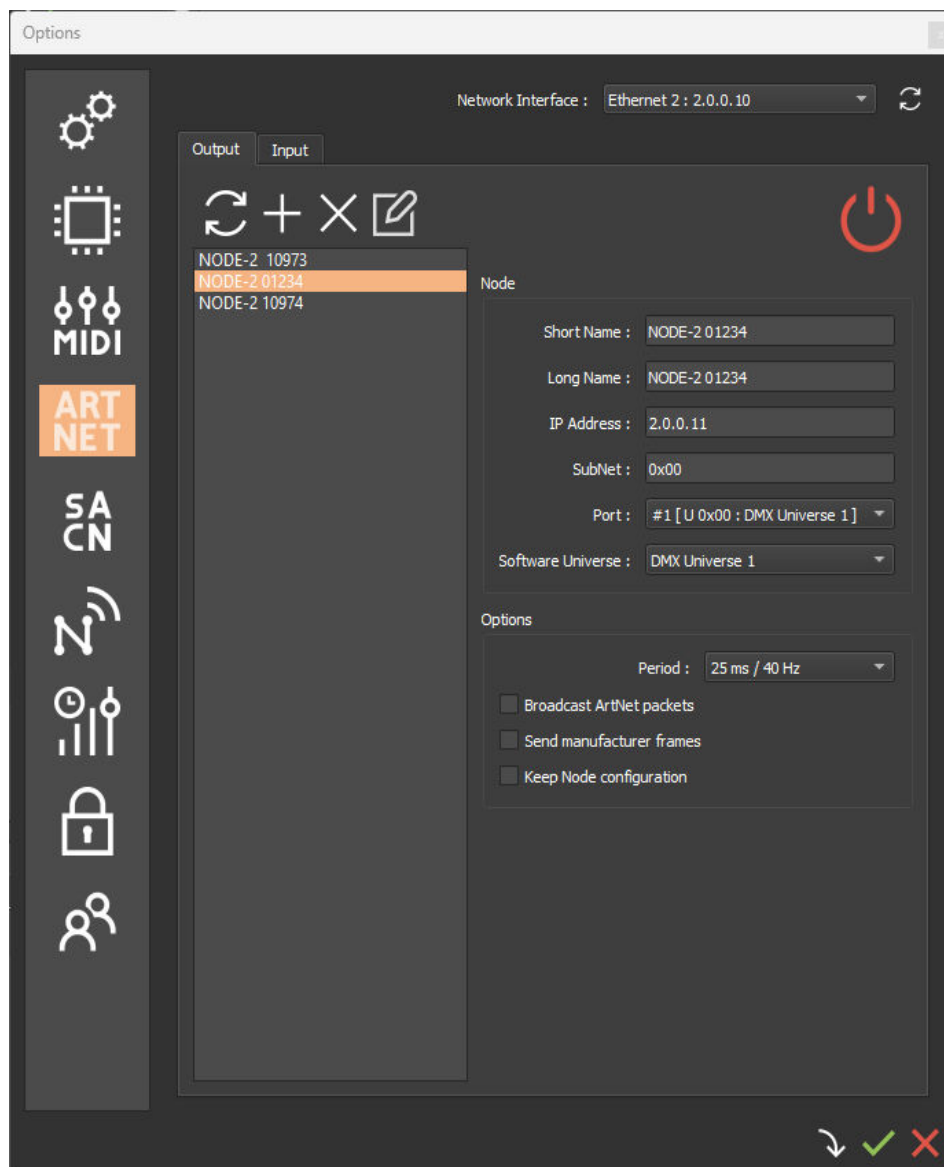

13. Troubleshooting

The device is not detected by the DeviceTool or USB software.	Unplug to restart the device.
	Change the USB cable
The device is not detected by the DeviceTool or Ethernet software.	Unplug to restart the device.
	Change the Ethernet cable
	Check the selection of Ethernet networks before opening.
The device is not detected on the network.	Check the mode of communication with LED signals and reconfigure the device via USB if necessary
	Verify that the IP addresses and subnet mask are configured correctly.
	Update the firmware of the device via the software or DeviceTool
	Update the software with the latest version and try again
	Open and allow the Communication Ports used by the device. Some local networks may require manual opening of the following UDP Ports: 8011 + 8012 for communication between the device and software.

If you experience unlisted issues, contact your seller or manufacturer directly to indicate your problem and receive a solution.

Product design and specifications are subject to change without prior notice.

Older devices (sold before 2020) are not compatible with PRO DMX version 2



191 Allée de Lauzard
34980 St Gély du Fesc, FRANCE
Web: www.chromateq.com
Email: info@chromateq.com
Phone: +33 952210755

Wechat: Chromateq
WhatsApp: +8613422062209
QQ: 2908265661



Guaranteed products: 1-3-5 years
Software pack: <https://chromateq.com/dmx-software-downloads/>
Copyright © 2021 - CHROMATEQ. All rights reserved.