

LTECH

UX8 TOUCH PANEL (RGBW)



Manual

www.ltech-led.com

Technical Specs

UX8 RGBW Touch Panel

Input Voltage:	5Vdc, 0.5A-1A (with a power adapter)
Output Signal:	RF 2.4GHz, DMX512
Control Mode:	RGBW, 4 Zones Control
Working Temp.:	-30°C~55°C
Package Size:	L132×W192×H50(mm)
Weight(N.W.):	230g
Weight(G.W.):	370g

R4-5A Constant Voltage Receiver (receiver is sold separately)

Input Voltage:	5-24Vdc
Current Load:	5A × 4CH Max. 20A
Output Power:	Max. 100W/240W/480W(5V/12V/24V)
Wireless Signal:	RF 2.4GHz
Working Temp.:	-30°C~55°C
Package Size:	L178×W48×H33(mm)
Weight(G.W.):	150g

R4-CC Constant Current Receiver (receiver is sold separately)

Input Voltage:	12-48Vdc
Output Voltage:	3-46Vdc
Output Current:	CC 350/700/1050mA×4CH
Output Power:	1.05W-48.3W×4CH Max 193.2W
Wireless Signal:	RF 2.4GHz
Working Temp.:	-30°C~55°C
Package Size:	L178×W48×H33(mm)
Weight(G.W.):	165g



Product Size:

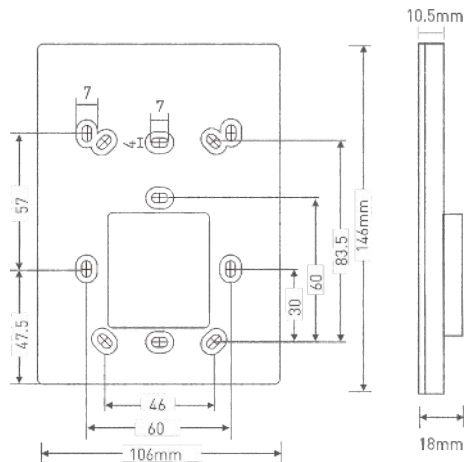

UX8 Touch Panel

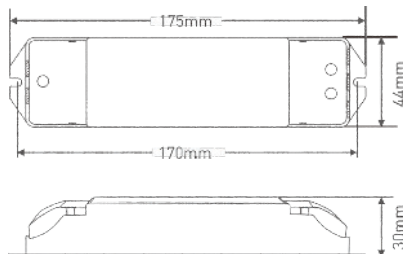

R4-5A/R4-CC Receiver

Terminals

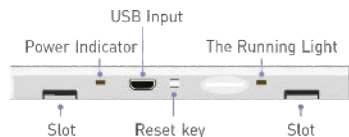
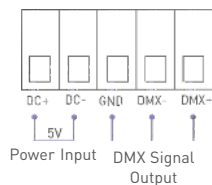
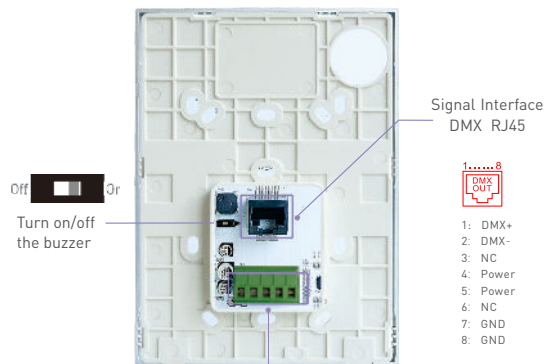

Installation Instruction:

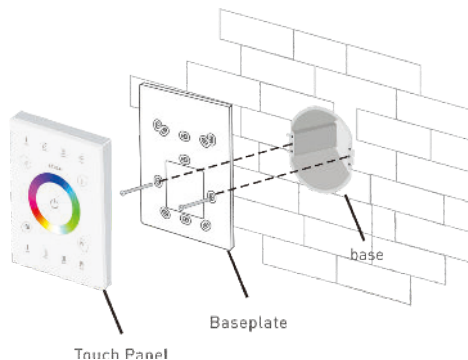

1. Install the back box into the wall. Typical boxes as below:

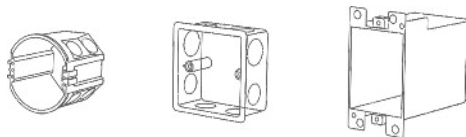

2. Use a straight screwdriver to pry the position shown:

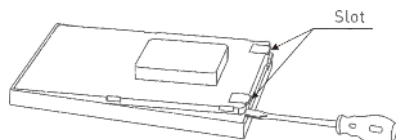

3. screw the baseplate and the back box in the wall firmly.

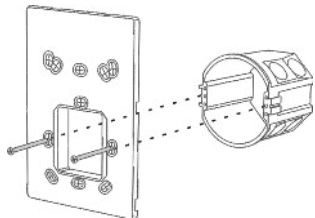

4. Connect in a right way and put the power adapter into the back box.

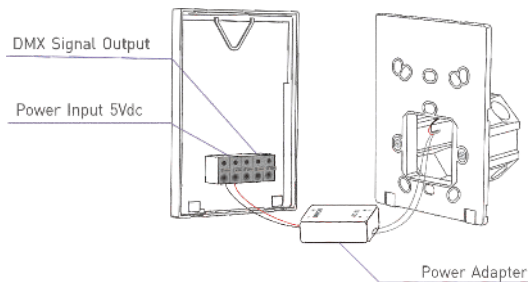

- 5 Embed the upper touch panel into the baseplate and then tap the bottom to press into the slots.

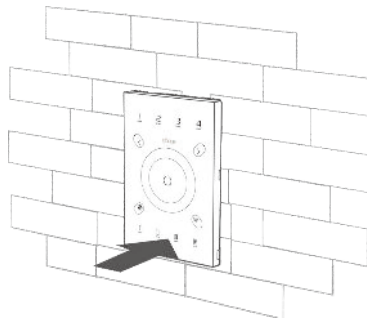
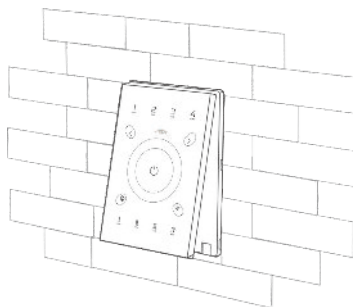

Key Functions

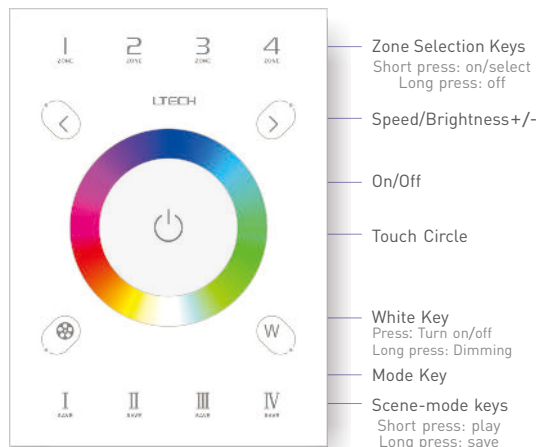

The Changing Mode (Press to Select):

1. Static Red
2. Static Green
3. Static Blue
4. Static Yellow
5. Static Purple
6. Static Cyan
7. Static White
8. RGB Jumping
9. 7 Colors Jumping
10. RGB Smooth
11. 7 Colors Smooth
12. Static Black

Application Composition

DMX512 Signal Output :

1. Touch panel (UX8)
2. Touch panel (UX8) + Remote (V8)
3. Touch panel (UX8) + WiFi master controller (WiFi-104)
4. Touch panel (UX8) + WiFi master controller (WiFi-104) + Remote (V8)

Wireless Control:

1. Touch panel (UX8) + Wireless receiver (R4-3A/5A, R4-CC)
2. Touch panel (UX8) + Remote (V8) + Wireless receiver (R4-3A/5A, R4-CC)
3. Touch panel (UX8) + WiFi master controller (WiFi-104) + Wireless receiver (R4-3A/5A, R4-CC)
4. Touch panel (UX8) + WiFi master controller (WiFi-104) + Remote (V8) + Wireless receiver (R4-3A/5A, R4-CC)

DMX Output Wiring

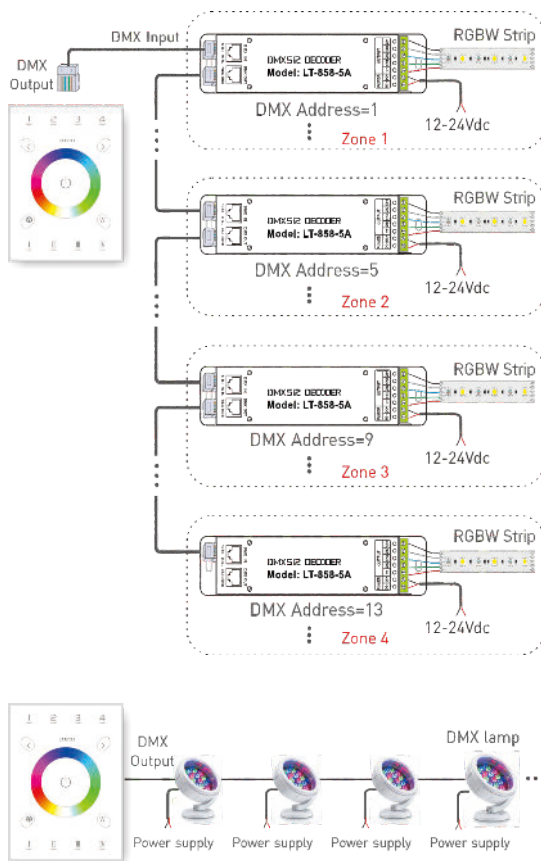

RF Wireless Wiring

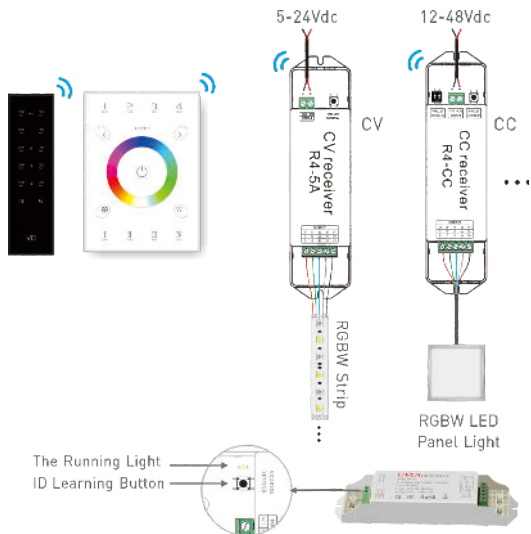

Match / Clear Code between UX8 (V8) & Receivers

Match Code:

Short press "ID learning button" on receiver (R4-3A/5A, R4-CC), then press any zone key on UX8 or V8, if the LEDs flicker once, match successfully.

Clear Code:

Long press "ID learning button" on receiver (R4-3A/5A, R4-CC) for 5 seconds, if the LEDs flicker twice, deactivate the matching successfully.

DMX System Wiring

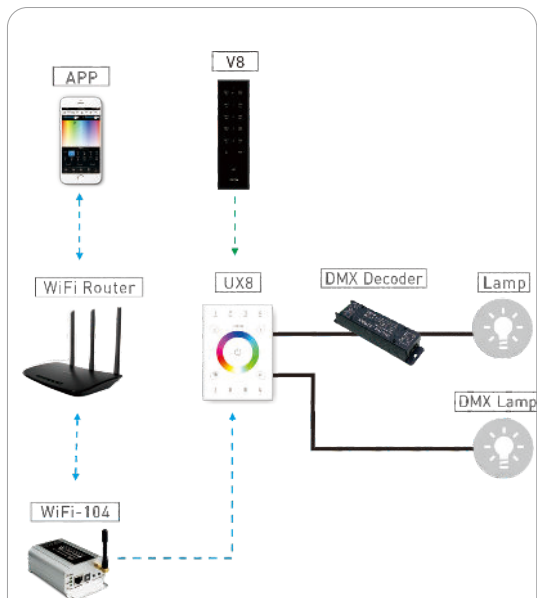

Match Code Sequence

1. Configure WiFi-104 with UX8, which enables the smart phone to control DMX device via WiFi-104.
2. Configure V8 with UX8, which enables V8 to control DMX device.

Wireless System Wiring

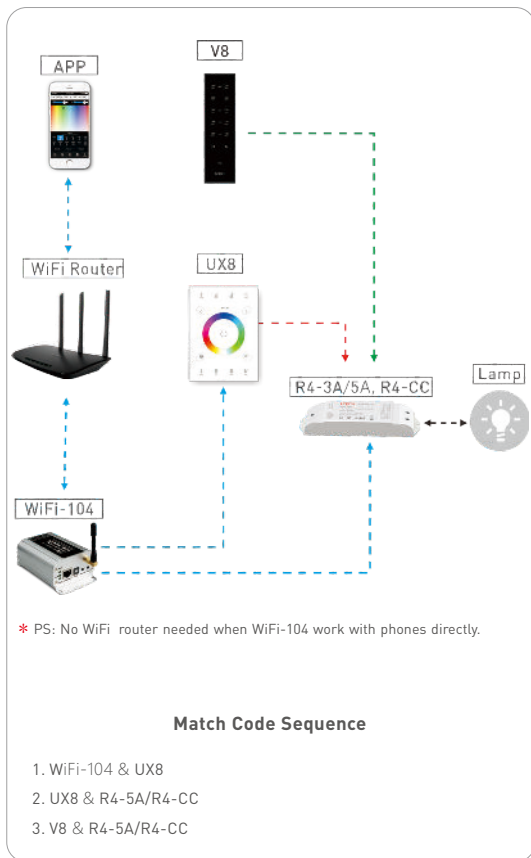

Match / Clear Code for UX8 & WiFi-104, V8, UX8

Match Code:

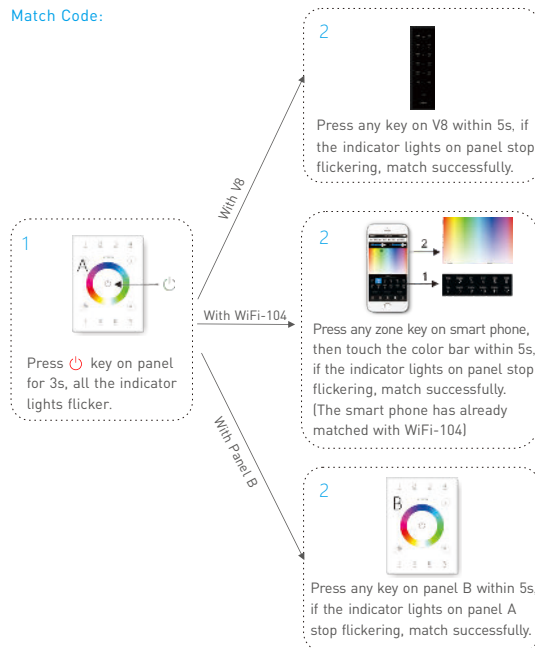

Clear Code:

