

# 96W DMX512 & RDM LED Driver(constant voltage)

09.96RD.04763



**Important:** Read All Instructions Prior to Installation

## Function introduction

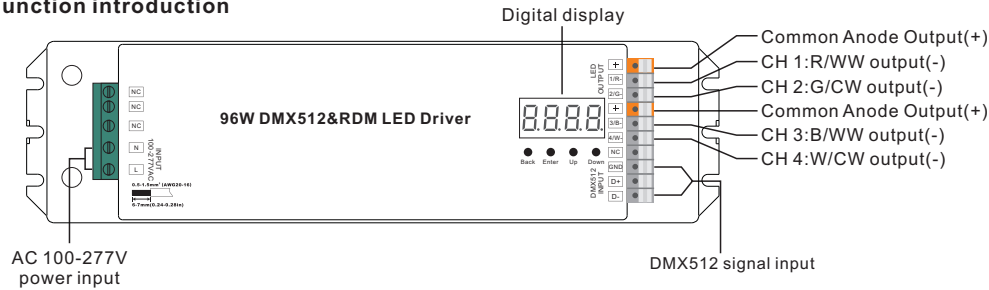

## Product Data

Output	LED Channel	4
	DC Voltage	24V DC
	Rated Current	Max. 4A/CH, CH1+CH2+CH3+CH4=4A
	Voltage Tolerance	±1%
	Rated Power	max. 96W (no minimum load required)
	Ripple & Noise (max.)	240mVp-p
	Line Regulation	±0.5%
	Load Regulation	±0.5%
	Setup Time	1500ms @ 115V, 1000ms @ 230V
Holdup Time (Typ.)	20ms @ 115V, 230V	
Input	Voltage Range	100-277V AC
	Frequency Range	50/60Hz
	Power Factor (Typ.)	> 0.90 @ 230VAC
	Total Harmonic Distortion	THD ≤ 15% (@ full load / 230VAC)
	Efficiency (Typ.)	90% @ 230VAC full load
	AC Current (Typ.)	1.2A @ 100VAC, 0.5A @ 230VAC
	Inrush Current (Typ.)	COLD START Max. 50A at 230VAC
Leakage Current	< 0.5mA /230VAC	
Control	Dimming Interface	DMX/RDM
	Dimming Range	0%-100%

	Dimming Method	Pulse Width Modulation
	Dimming Curve	Linear, Logarithmic
Protection	Over Current	Yes, recovers automatically after fault condition is removed
	Over Temperature	Yes, recovers automatically after fault condition is removed
Environment	Working Temp.	-20°C ~ +50°C
	Max. Case Temp.	75°C
	Working Humidity	10% ~ 95% RH non-condensing
	Storage Temp. & Humidity	-40°C ~ +80°C, 10% ~ 95% RH
Safety & EMC	Safety Standards	UL8750, CAN/CSA C22.2 No. 250.13-14, EN61347-1, EN61347-2-13 approved
	Withstand Voltage	I/P-O/P: 3.75KVAC
	Isolation Resistance	I/P-O/P: 100M Ohms / 500VDC / 25°C / 70% RH
	EMC Emission	EN55015, EN61000-3-2, EN61000-3-3
Others	EMC Immunity	EN61547, EN61000-4-2,3,4,5,6,8,11, surge immunity Line-Line 1KV
	MTBF	193.6K hrs min. @ 230VAC full load and 25°C ambient temperature
	Dimension	244*64*32mm (L*W*H)

- Built-in DMX512 interface, support RDM bi-directional communication
- 100-277VAC wide input voltage
- 4 DMX512 Addresses, 4 Channels Output . DMX channel quantity from 1CH-4CH settable
- To control single color, dual color, RGB/RGBW LED lighting
- PWM output resolution ratio 8bit , 16bit settable.
- Output PWM frequency from 500HZ ~ 30K HZ settable.
- Output dimming curve gamma value from 0.1 ~ 9.9 settable.
- Compatible with universal DMX512 consoles
- Class II power supply, full isolated plastic case
- High power factor and efficiency
- Galvanic isolation
- IP20 rating, suitable for indoor LED lighting applications

## Safety & Warnings

- DO NOT install with power applied to device.
- DO NOT expose the device to moisture.

## Operation

### Button introduction

Up, Down button is for menu selection. After power on the decoder, if keep on clicking Up button, you will find below menu on display:

DMX signal indicator ● : When DMX signal input is detected, the indicator on the display following after **R** turns on red

**R**.XXX·



- A.XXX** Means DMX address. factory defaults setting is 001.
- CHXX** Means DMX channels quantity.
- BEXX** Means Bit (8bit or 16bit). factory defaults setting is 16bit
- PFXX** Means output PWM frequency. factory defaults setting is 1K HZ
- GA.XX** Means output dimming curve gamma value, factory defaults setting is ga 1.5
- DP.XX** Means Decoding mode, factory defaults setting is dp1.1

By holding button Back + Enter together at the same time over 5 seconds until the display go off, it will restore default settings .

**1. DMX address setting (factory default is A001):**

select menu **A.XXX** , click button “Enter”, display flashes, then click or hold button “Up” / “Down” to set DMX address (click is slow, hold is fast.), then click button“Back” to confirm.

**2. DMX channel quantity setting (factory default is CH04):**

Select menu **CHXX** , click button “Enter”, display flashes, then click button “Up” / “Down” to set DMX channel quantity , then click button“Back” to confirm.

For example the DMX address is already set 001.

CH01=1 DMX address for all the output channels, which are all address 001.

CH02=2 DMX addresses , output 1&3 is address 001, output 2,4 is address 002

CH03=3 DMX addresses, output 1, 2 is address 001,002, output 3,4 is address 003

CH04=4 DMX addresses, output 1,2,3,4 is address 001,002,003,004

**3. PWM output resolution Bit setting (factory default is bt16):**

select menu **BEXX** , click button “Enter”, display flashes, then click button “Up” / “Down” to choose 08 or 16 bit, then click button“Back” to confirm.

**4. output PWM frequency setting (factory default is PF01 1KHz):**

select menu **PFXX** , click button “Enter”, display flashes, then click button “Up” / “Down” to choose 00~30, then click button“Back” to confirm. 00=500HZ, 01=1kHz, 02=2kHz....30=30kHz.

**5. output dimming curve gamma value setting (factory default is gA1.5):**

select menu **GA.XX** , click button “Enter”, display flashes, then click or hold button “Up” / “Down” to choose 0.1~9.9, then click button“Back” to confirm.

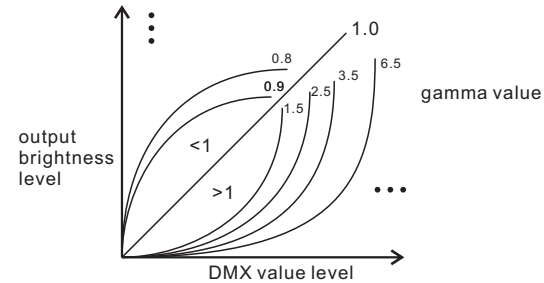

**6. DMX decoding mode setting (factory default is dP1.1):**

Select menu **DP.XX** , click button “Enter”, display flashes, then click or hold button “Up” / “Down” to choose the decoding mode, then click button“Back” to confirm. “dPxx” means the DMX address quantity used for control of corresponding PWM output channel quantity. 1st “x” is DMX address quantity, 2nd “x” is PWM channel quantity.

Fine dimming: the fine dimming effect can only be visible when the dimming curve gamma value is set lower than 1.4, and the lower the value is, the more visible the fine dimming effect will be.

**DMX address is 001, CH01**

DMX Console Slider number	dp1.1	dp2.1
DMX channel		
1	for all output dimming	for all output dimming
2	No use	for all output fine dimming

**DMX address is 001, CH02**

DMX Console Slider number	dp1.1	dp2.1	dp3.2
DMX channel			
1	for output 1&3 dimming	for output 1&3 dimming	for output 1&3 dimming
2	for output 2,4 dimming	for output 1&3 fine dimming	for output 2,4 dimming
3		for output 2,4 dimming	for all output dimming
4		for output 2,4 fine dimming	

**DMX address is 001, CH03**

DMX Console Slider number	dp1.1	dp2.1	dp4.3	dp5.3
DMX channel				
1	for output 1 dimming	for output 1 dimming	for output 1 dimming	for output 1 dimming
2	for output 2 dimming	for output 1 fine dimming	for output 2 dimming	for output 2 dimming
3	for output 3,4 dimming	for output 2 dimming	for output 3,4 dimming	for output 3,4 dimming
4		for output 2 fine dimming	for all output master dimming	for all output master dimming
5		for output 3,4 dimming		strobe effects
6		for output 3,4 fine dimming		

**DMX address is 001, CH04 (factory default)**

DMX Console Slider number	dp1.1	dp2.1	dp5.4	dp6.4
DMX channel				
1	for output 1 dimming	for output 1 dimming	for output 1 dimming	for output 1 dimming
2	for output 2 dimming	for output 1 fine dimming	for output 2 dimming	for output 2 dimming
3	for output 3 dimming	for output 2 dimming	for output 3 dimming	for output 3 dimming
4	for output 4 dimming	for output 2 fine dimming	for output 4 dimming	for output 4 dimming
5		for output 3 dimming	for all output master dimming	for all output master dimming
6		for output 3 fine dimming		strobe effects
7		for output 4 dimming		
8		for output 4 fine dimming		

**The data definitions for strobe channel are as follows:**

- {0, 7},//undefined
- {8, 65},//slow strobe-->fast strobe
- {66, 71},//undefined
- {72, 127},//slow push fast close
- {128, 133},//undefined
- {134, 189},//slow close fast push
- {190, 195},//undefined
- {196, 250},//random strobe
- {251, 255},//undefined

**The supported RDM PIDs are as follows:**

DISC\_UNIQUE\_BRANCH  
 DISC\_MUTE  
 DISC\_UN\_MUTE  
 DEVICE\_INFO  
 DMX\_START\_ADDRESS  
 IDENTIFY\_DEVICE  
 SOFTWARE\_VERSION\_LABEL  
 DMX\_PERSONALITY  
 DMX\_PERSONALITY\_DESCRIPTION  
 SLOT\_INFO  
 SLOT\_DESCRIPTION  
 MANUFACTURER\_LABEL  
 SUPPORTED\_PARAMETERS

**Restore to Factory Default Setting**

Press and hold down both "Back" and "Enter" keys until the digital display turns off, then release the keys, system will reset and the digital display will turn on again, all settings will be restored to factory default.

Default settings are as follows:

DMX Address Code: a001  
 DMX Address Quantity: SW1=0: ch04, SW1=1: ch03  
 PWM Resolution Mode: bt16  
 PWM Frequency: pf01  
 Gamma: ga1.5  
 Decoding Mode: dp1.1

**Wiring diagram**

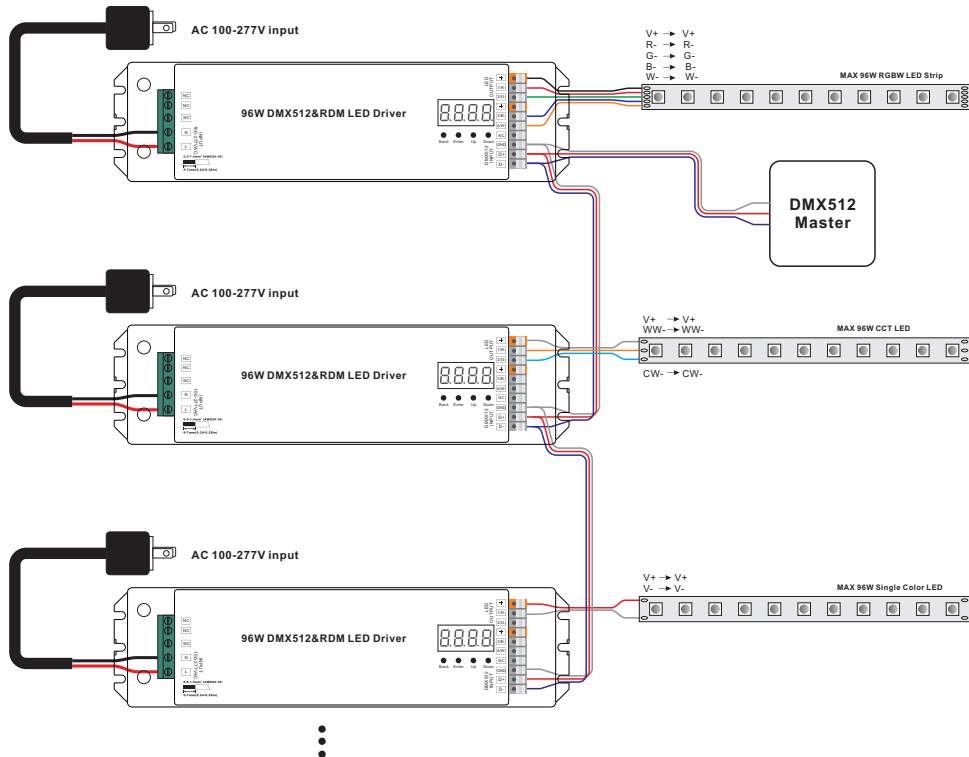

**Product Dimension**

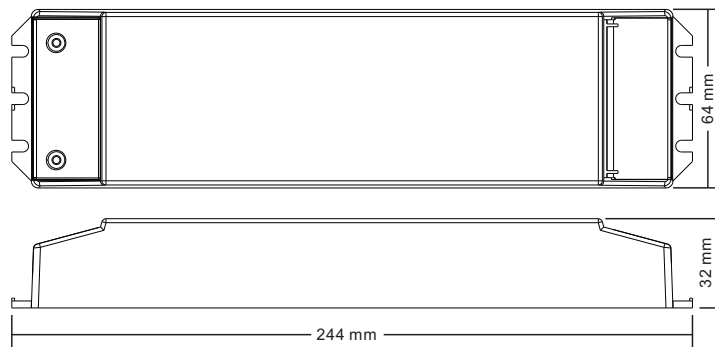

**Installation**

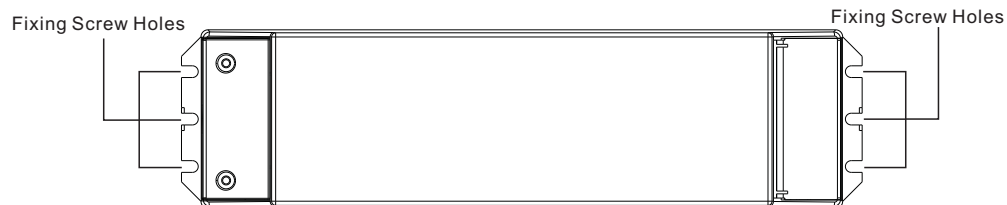

**Note:** when mounting the driver, please choose any one of the three fixing screw holes to fix with a screw at each end.