

Ultra-Pro 24CH RDM DMX512 Decoder

70060027



Important: Read All Instructions Prior to Installation

Function introduction

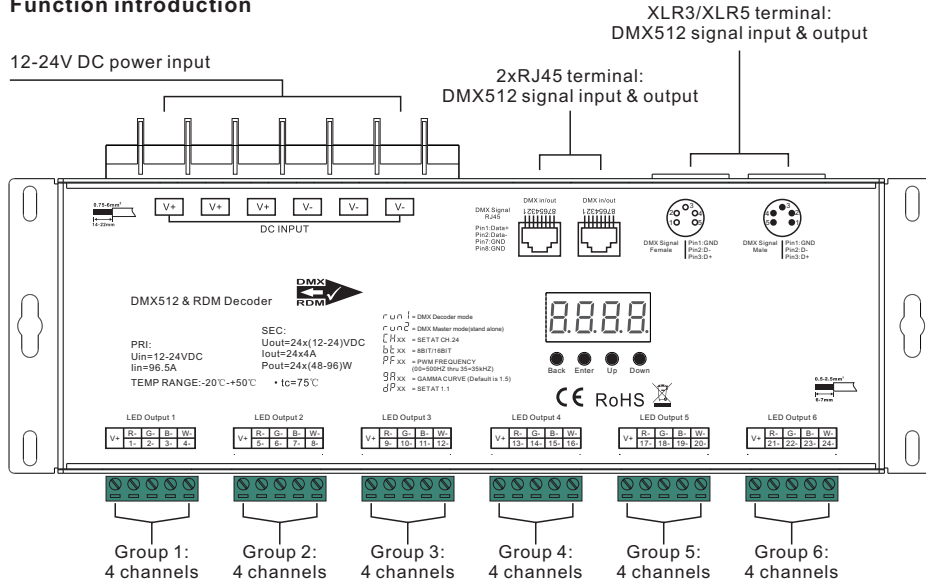

Product Data

Input Voltage	Output Current	Output Power	Remarks	Size(LxWxH)	Protection
12-24VDC	24x4A	24x(48-96)W	Constant voltage	264.5X83X42mm	Short circuit

- Master & decoder mode, RDM function
- Metal housing, digital display to show data directly, easily to set and show DMX address.
- With multiple kinds of DMX in/out ports: RJ 45, XLR , pluggable terminal blocks.
- Total 24 PWM output channels, common anode. DMX channel quantity 1CH or 24CH settable.
- PWM output resolution ratio 8bit , 16bit settable.
- Output PWM frequency from 500HZ ~ 35K HZ settable.
- Output dimming curve gamma value from 0.1 ~ 9.9 settable.
- Decoding mode settable.
- Galvanic isolation

Safety & Warnings

- DO NOT install with power applied to device.
- DO NOT expose the device to moisture.

Operation

Before you do other settings, please set the device to be Master or Decoder mode.

run1 = DMX Decoder mode, run2 = DMX Master mode(stand alone).

Keep on clicking Down button, to get run1 or run2, then click Enter, then click Down button to choose 1 or 2, then click Back button.

I. For run2 DMX Master mode: After set the device as run2 (Master mode), if keep on clicking Up button, you will find below menu on display:

8.8.8.8 Means brightness for each output PWM channel. First 01 means PWM output channel 1 and it is selectable from 01 to 24 by clicking "UP" or "Down" button. Second 01 means brightness level, click "Enter" button, the display flashes, then click "UP" or "Down" button to select from 00-99-FL, which means 0%-99%-100% brightness, then click "Back" button to confirm.



● ● ● ●
Back Enter Up Down

8.8.8.8 means chasing effects, total 4 effects selectable from 01-04. Click "Up" or "Down" button to select the menu, then click "Enter" button to enter into the effect, then click "Up" or "Down" button to select from 01-04.

CA01: Fade-up (0%-100%) and fade-down (100%-0%) of output 1, then output 2, output 3,, output 24, output 1,, cycling chasing

CA02: Fade-up (0%-100%) of output 1, then simultaneous fade-down (100%-0%) of output 1 and fade-up (0%-100%) of output 2, simultaneous down of output 2 and up of output 3,, simultaneous down of output 23 and up of output 24, simultaneous down of output 24 and up of output 1,, cycling chasing

CA03: Fade-up (0%-100%) of output 1, then output 2, output 3,, output 24, output 1,, cycling chasing

CA04: Fade-down (100%-0%) of output 1, then output 2, output 3,, output 24, output 1,, cycling chasing

8.8.8.8 means chasing speed, it is selectable from 01-09, 01 is the slowest, 09 is the fastest.

II. For run1 DMX decoder mode: After set the device as run1 (Decoder mode), if keep on clicking Up button, you will find below menu on display:

8.XXX **DMX signal indicator** : When DMX signal input is detected, the indicator on the display following after **8** turns on red

8.XXX Means DMX address. factory defaults setting is 001.

88XX Means DMX channels quantity. factory defaults setting is Ch24

88XX Means Bit (8bit or 16bit). factory defaults setting is 16bit

88XX Means output PWM frequency. factory defaults setting is 1K HZ

88XX Means output dimming curve gamma value, factory defaults setting is ga 1.5

88XX Means Decoding mode, factory defaults setting is dp1.1

run1 Means the device at run1 mode (DMX decoder mode).

By holding button Back + Enter together at the same time over 5 seconds until the display go off, it will restore default settings .

Wiring diagram

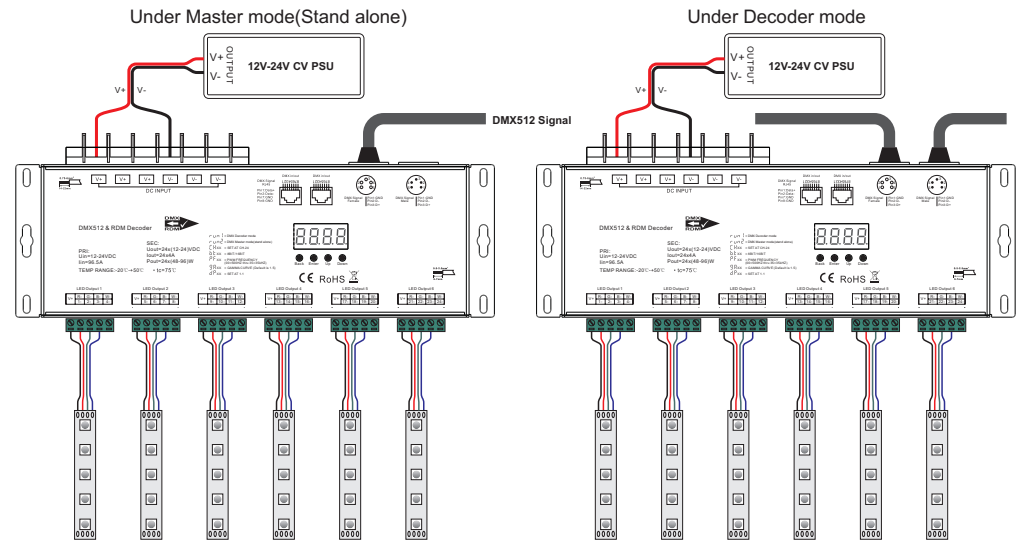

1. DMX address setting:

Select menu **8.XXX** , click button "Enter", display flashes, then click or hold button "Up" / "Down" to set DMX address (click is slow, hold is fast.), then click button "Back" to confirm.

2. DMX channel quantity setting:

Select menu **88XX** , click button "Enter", display flashes, then click button "Up" / "Down" to set DMX channel quantity , then click button "Back" to confirm.

For example the DMX address is already set as 001.

CH01=1 DMX address for all the output channels, which are all address 001.

CH24=24 DMX addresses, output 1-24 is address 001-024 respectively.

The supported RDM PIDs are as follows:

DISC_UNIQUE_BRANCH
DISC_MUTE
DISC_UN_MUTE
DEVICE_INFO
DMX_START_ADDRESS
IDENTIFY_DEVICE
SOFTWARE_VERSION_LABEL
DMX_PERSONALITY
DMX_PERSONALITY_DESCRIPTION
SLOT_INFO
SLOT_DESCRIPTION
MANUFACTURER_LABEL
SUPPORTED_PARAMETERS

RDM Discovery Indication:

When using RDM to discover the device, the digital display will flash and the connected lights will also flash at the same frequency to indicate. Once the display stops flashing, the connected light also stops flashing.

Short circuit protection

If short circuit of the connected load is detected, the display will flash to alarm and the load will be forced to open circuit status. Once the fault is removed, the decoder will recover after re-powered on.

Restore to Factory Default Setting

Press and hold down both "Back" and "Enter" keys until the digital display turns off, then release the keys, system will reset and the digital display will turn on again, all settings will be restored to factory default.

Default settings are as follows:

DMX Address Code: a001

DMX Address Quantity: SW1=0: ch24, SW1=1: ch01

PWM Resolution Mode: bt16

PWM Frequency: pf01

Gamma: ga1.5

Decoding Mode: dp1.1